

MONTAGGIO DISTRIBUTORI PNEUMATICI A COMANDO MANUALE

ASSEMBLAGGIO DISPOSITIVI MANUALI CON MICROVALVOLA

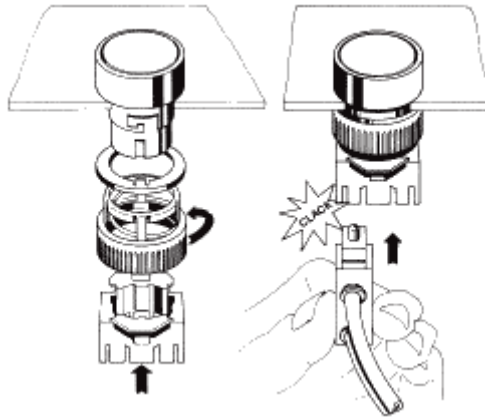

SMONTAGGIO DELLA MICROVALVOLA DAL DISPOSITIVO

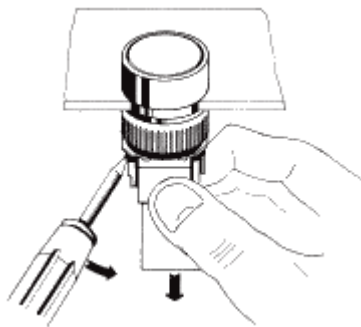

ANELLI DI RIDUZIONE

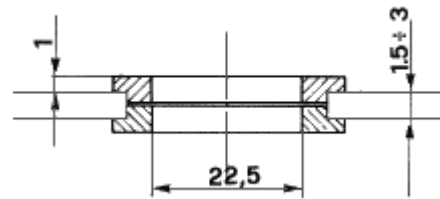

MONTAGGIO DISPOSITIVI A PANNELLO

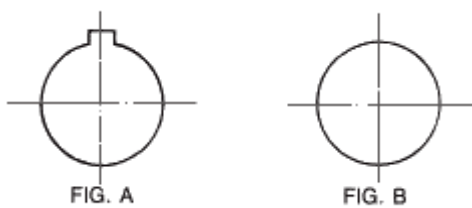

POSIZIONAMENTO FORI SUL PANNELLO

