

**FIXINGS PNEUMO-HYDRAULICS UNITS** **SERIES US**

**TYPE CE**

**REAR HINGE – ALUMINIUM MODEL CE**

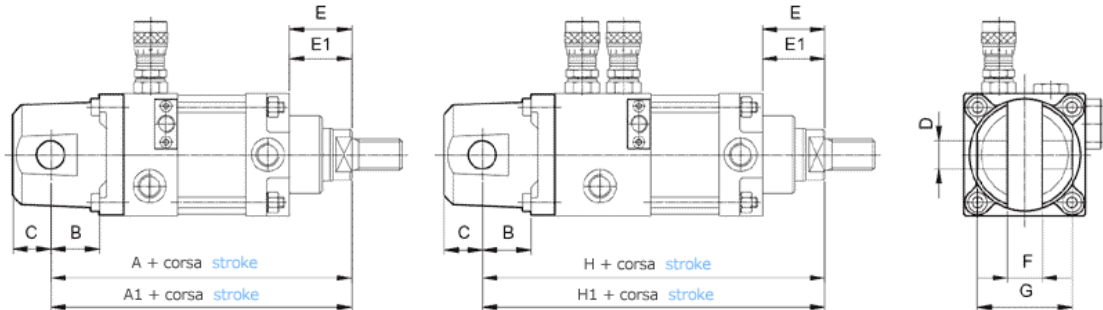

BORE	A	A1*	B	C	D H8	E	E1*	F	G	H	H1*
50	178	198	20	16	12	41.5	61.5	15	37		
63	190	210	30	20	16	41.5	61.5	20	55	213	233
80	221	237	35	25	18	54.5	70.5	25	75	243	259
100	226	242	35	25	20	54.5	70.5	25	75	248	264
125	241	261	45	25	25	58.5	78.5	30	80	263	283
160	287.5	312.5	45	35	25	64	89	35	95	300.5	325.5
200	346	371	45	38	25	73	98	75	160	353	378

\* with gradual closing (model DS)

**TYPE FA**

**FRONT FLANGE – ALUMINIUM MODEL FA**

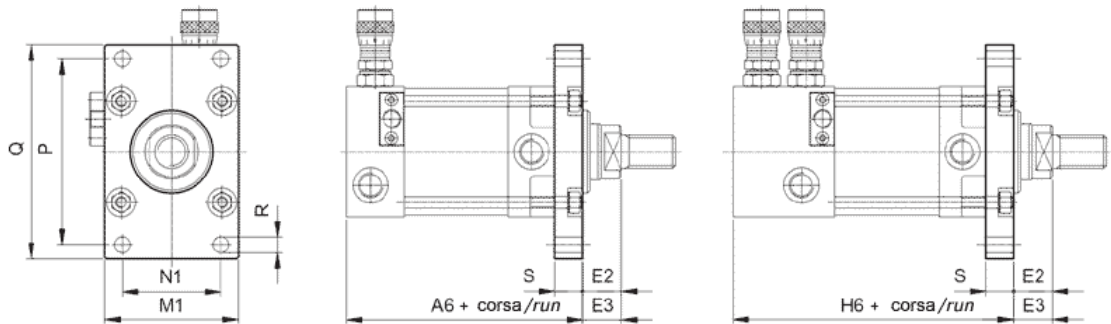

BORE	A6	E2	E3*	H6	M1	N1	P	Q	R	S
50	118.5	30.5	50.5	0	60	43	89	105	6.5	11
63	122.5	26.5	46.5	145.5	72	54.5	100	115	8.5	15
80	135	37.5	53.5	157	90	70	130	150	8.5	17
100	143	34.5	50.5	165	110	83.5	141	166	10.5	20
125	143	38.5	58.5	165	135	102.5	155	185	10.5	20
160	180	39	64	193	170	133	210	250	16	25
200	230	48	73	237	210	162	320	360	17	25

\* with gradual closing (model DS)

## TYPE SL



intermediate hinge in brass

## INTERMEDIATE HINGE – BRASS MODEL SL

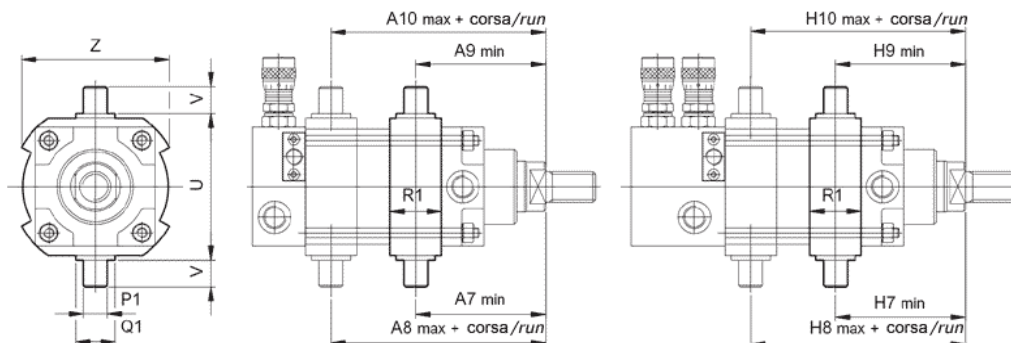

BORE	A7	A8	A9*	A10*	H7	H8	H9*	H10*	P1f6	Q1	R1	U	V	Z*
50	84	93.5	104	113.5					16	24	35	69	16	65
63	86.5	91	106.5	111	86.5	91	106.5	111	20	30	40	83	20	85
80	107	102	123	118	107	102	123	118	20	30	55	108	20	99
100	117	102	133	118	117	102	133	118	25	35	65	131	25	118
125	120.5	106	141	126	120.5	106	141	126	25	35	65	159	25	145
160	141.5	127.5	166.5	152.5	141.5	127.5	166.5	152.5	35	45	75	194	35	188
200	178	177	203	202	178	177	203	202	35	45	80	242	35	228

\* with gradual closing (model DS)

## TYPE FF



female fork in zinc plated steel, complete of pin and clips

## FEMALE FORK – ZINC PLATED STEEL MODEL FF

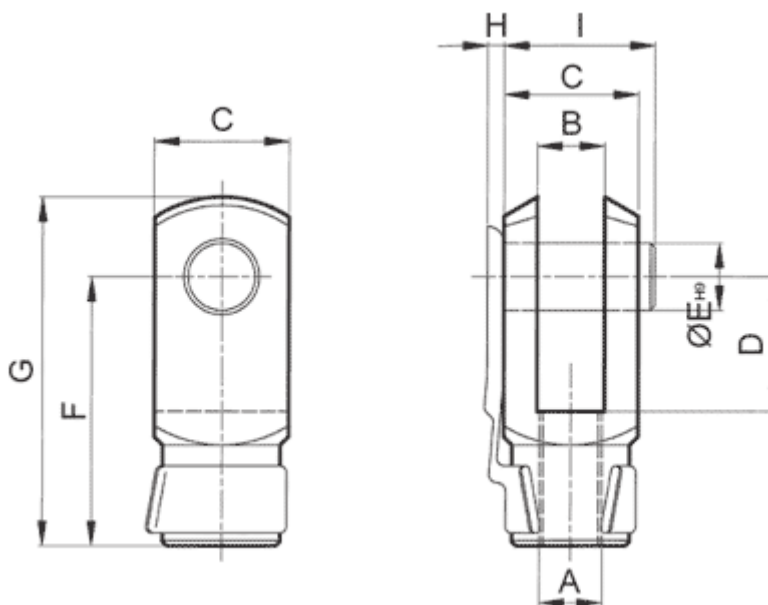

Ø mm	A	B	C	D	E	F	G	H	I
50	M16x1,5	16	32	32	16	64	83	4	36
63	M16x1,5	16	32	32	16	64	83	4	36
80	M20x1,5	20	40	40	20	80	105	4	44
100	M20x1,5	20	40	40	20	80	105	4	44
125	M27x2	30	55	54	30	110	148	-	65
160	M36x2	35	70	72	35	144	188	-	84
200	M36x2	35	70	72	35	144	188	-	84



## TYPE PI



fixing feet  
in  
aluminium

## FIXING FEET – ALUMINIUM MODEL PI

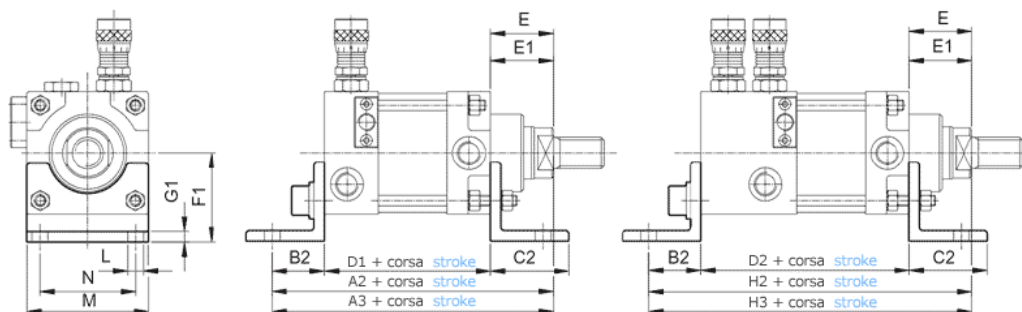

ALESAGGIO	A2	A3*	B2	C2	D1	D2	E	E1*	F1	G1	H2	H3*	L	M	N
50	183	203	35	45	106.5		41.5	61.5	45	6			9	60	45
63	183	203	35	45	106.5	129.5	41.5	61.5	50	6	206	226	9	70	55
80	214	230	43	60	116.5	138.5	54.5	70.5	60	6	236	252	12	90	70
100	219	235	43	60	121.5	143.5	54.5	70.5	73	6	241	257	14	110	85
125	232	252	52	70	121.5	143.5	58.5	78.5	91	8	254	274	16	140	100
160	279.5	304.5	62	80	153.5	166.5	64	89	115	8	292.5	317.5	18	170	130
200	338	363	62	80	203	210	73	98	135	8	345	370	20	210	170

\* with gradual closing (model DS)

## TYPE FP



rear flange  
in  
aluminium

## REAR FLANGE – ALUMINIUM MODEL FP

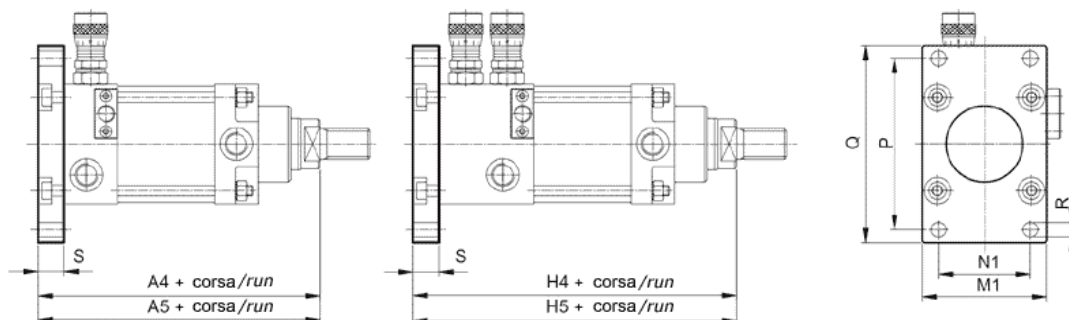

ALESAGGIO	A4	A5*	H4	H5*	M1	N1	P	Q	R	S
50	159	179			60	43	89	105	6.5	11
63	163	183	186	206	72	54.5	100	115	8.5	15
80	188	204	210	226	90	70	130	150	8.5	17
100	196	212	218	234	110	83.5	141	166	10.5	20
125	200	220	222	242	135	102.5	155	185	10.5	20
160	242.5	267.5	255.5	280.5	170	133	210	250	16	25
200	301	326	308	333	210	162	320	360	17	25

\* with gradual closing (model DS)



**TIPO KK**

**RADIAL-AXIAL JOINT - ZINC PLATED STEEL MODEL KK**

radial-axial joint  
in  
zinc plated  
steel

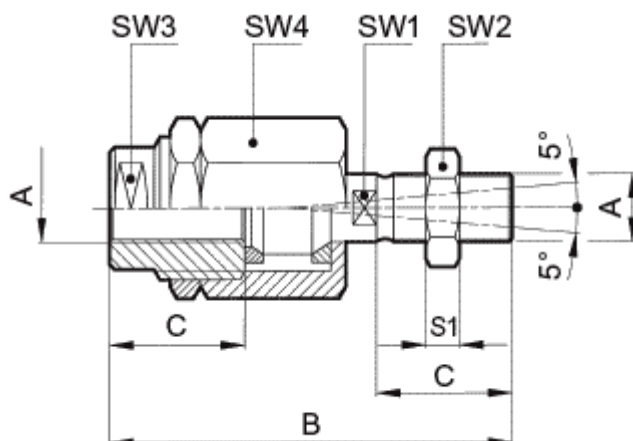

ALESAGGIO	A	B	C	S1	SW1	SW2	SW3	SW4
50	M16X1,5	103	32	8	20	24	30	42
63	M16X1,5	103	32	8	20	24	30	42
80	M20X1,5	119	40	10	20	30	30	42
100	M20X1,5	119	40	10	20	30	30	42

**TYPE KJ**

**OSCILLATING CLEVIS – ZINC PLATED STEEL MODEL KJ**



oscillating  
clevis  
in  
zinc plated  
steel

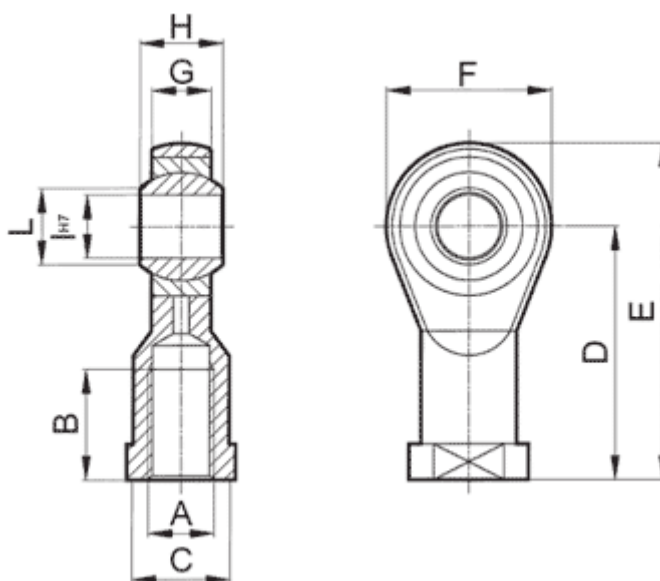

Ø mm	A	B	C	D	E	F	G	H	I	L
50	M16x1,5	28	22	64	85	42	15	21	16	19,3
63	M16x1,5	28	22	64	85	42	15	21	16	19,3
80	M20x1,5	33	30	77	102	50	18	25	20	24,3
100	M20x1,5	33	30	77	102	50	18	25	20	24,3
125	M27x2	51	41	110	145	70	25	37	30	34,8
160	M36x2	56	50	125	165	80	28	43	35	37,7
200	M36x2	56	50	125	165	80	28	43	35	37,7

**TYPE SEC**

**PIN FOR HINGE – ZINC PLATED STEEL MODEL SEC**





pin for hinge  
in  
zinc plated  
steel

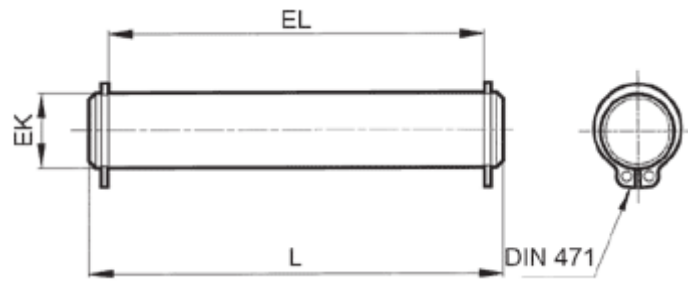

$\varnothing$ mm	EK e8	EL	L
50	12	38	44
63	16	56	62
80	18	76	82
100	20	76	82
125	25	82	88
160	25	97	103
200	25	162	168

