

FISSAGGI OLEOPNEUMATICI

SERIE UD

TIPO CE

CERNIERA POSTERIORE – ALLUMINIO, COD. CE



Cerniera posteriore in alluminio

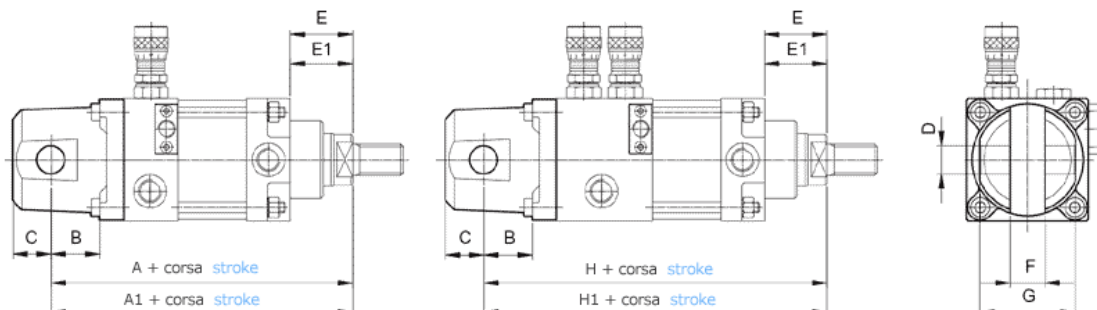

ALESAGGIO	A	A1*	B	C	D H8	E	E1*	F	G	H	H1*
50	178	198	20	16	12	41.5	61.5	15	37		
63	190	210	30	20	16	41.5	61.5	20	55	213	233
80	221	237	35	25	18	54.5	70.5	25	75	243	259
100	226	242	35	25	20	54.5	70.5	25	75	248	264
125	241	261	45	25	25	58.5	78.5	30	80	263	283
160	287.5	312.5	45	35	25	64	89	35	95	300.5	325.5
200	346	371	45	38	25	73	98	75	160	353	378

* con deceleratore idraulico in uscita (cod. DS)

TIPO FA

FLANGIA ANTERIORE – ALLUMINIO, COD. FA



Flangia anteriore in alluminio

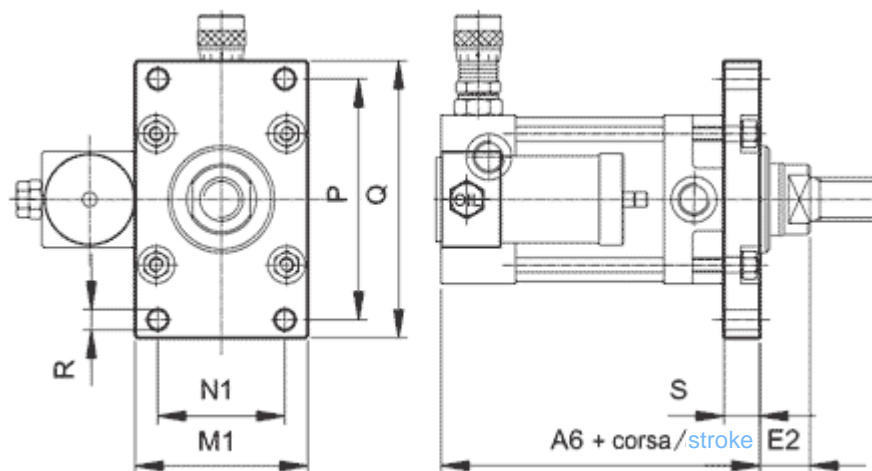

Ø mm	A6	E2	M1	N1	P	Q	R	S
50	117,5	30,5	60	43	89	105	6,5	11
63	122,5	26,5	72	54,5	100	115	8,5	15
80	135	37,5	90	70	130	150	8,5	17
100	143	34,5	110	83,5	141	166	10,5	20

TIPO IFF

FORCELLA FEMMINA - ACCIAIO ZINCATO, COD. IFF



Forcella femmina in acciaio zincato

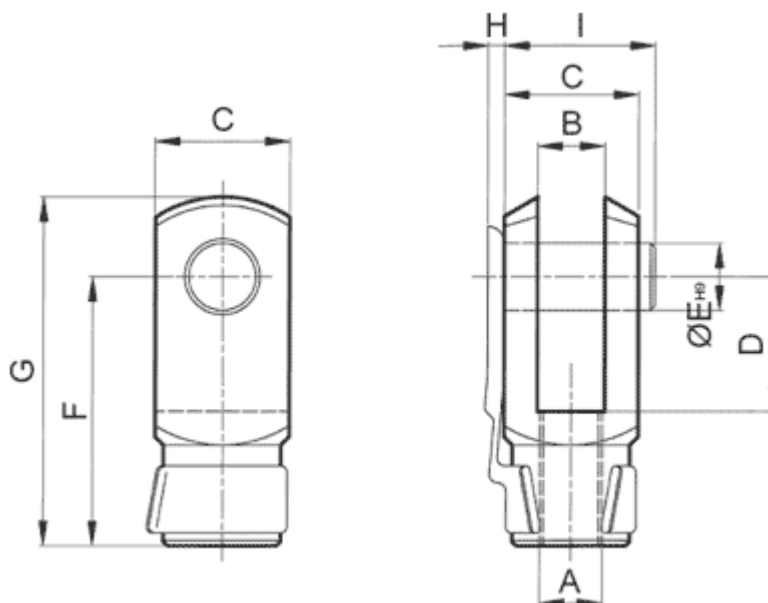

Ø mm	A	B	C	D	E	F	G	H	I
50	M16x1,5	16	32	32	16	64	83	4	36
63	M16x1,5	16	32	32	16	64	83	4	36
80	M20x1,5	20	40	40	20	80	105	4	44
100	M20x1,5	20	40	40	20	80	105	4	44
125	M27x2	30	55	54	30	110	148	-	65
160	M36x2	35	70	72	35	144	188	-	84
200	M36x2	35	70	72	35	144	188	-	84

TIPO PI

PIEDINI – ACCIAIO ZINCATO, COD. PI



Piedini di fissaggio in acciaio zincato

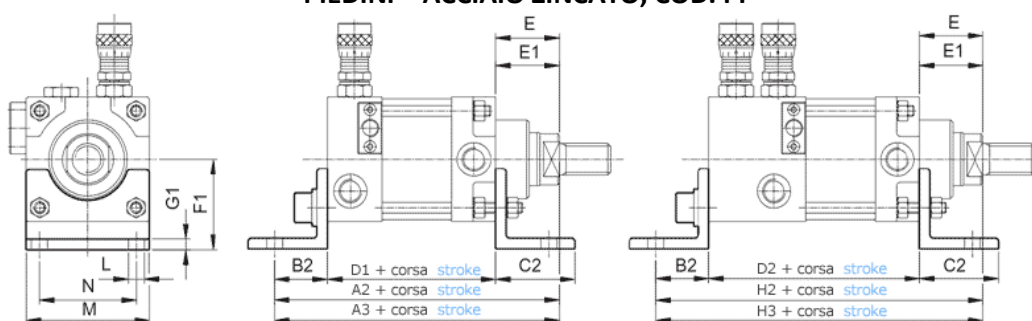

ALESAGGIO	A2	A3*	B2	C2	D1	D2	E	E1*	F1	G1	H2	H3*	L	M	N
50	183	203	35	45	106.5		41.5	61.5	45	6			9	60	45
63	183	203	35	45	106.5	129.5	41.5	61.5	50	6	206	226	9	70	55
80	214	230	43	60	116.5	138.5	54.5	70.5	60	6	236	252	12	90	70
100	219	235	43	60	121.5	143.5	54.5	70.5	73	6	241	257	14	110	85
125	232	252	52	70	121.5	143.5	58.5	78.5	91	8	254	274	16	140	100
160	279.5	304.5	62	80	153.5	166.5	64	89	115	8	292.5	317.5	18	170	130
200	338	363	62	80	203	210	73	98	135	8	345	370	20	210	170

* con deceleratore idraulico in uscita (cod. DS)



TIPO FP
FLANGIA POSTERIORE – ALLUMINIO, COD. FP

Flangia posteriore in alluminio

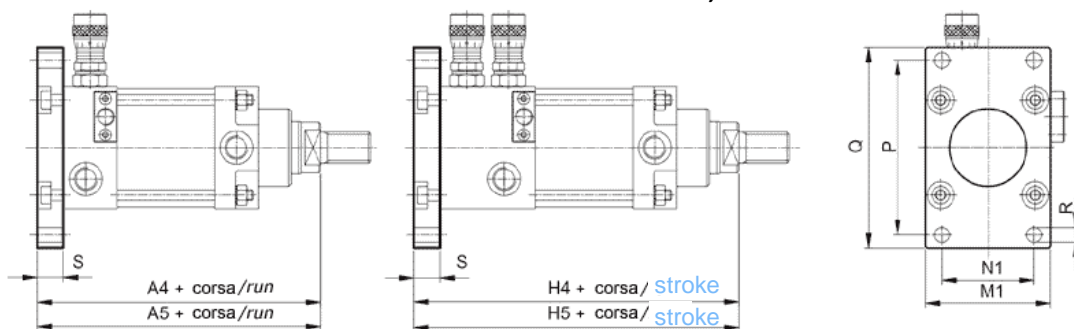

ALESAGGIO	A4	A5*	H4	H5*	M1	N1	P	Q	R	S
50	159	179			60	43	89	105	6.5	11
63	163	183	186	206	72	54.5	100	115	8.5	15
80	188	204	210	226	90	70	130	150	8.5	17
100	196	212	218	234	110	83.5	141	166	10.5	20
125	200	220	222	242	135	102.5	155	185	10.5	20
160	242.5	267.5	255.5	280.5	170	133	210	250	16	25
200	301	326	308	333	210	162	320	360	17	25

* con deceleratore idraulico in uscita (cod. DS)

TIPO IKK
SNODO RADIALE-ASSIALE - ACCIAIO ZINCATO, COD. IKK

Snodo radiale – assiale in acciaio zincato

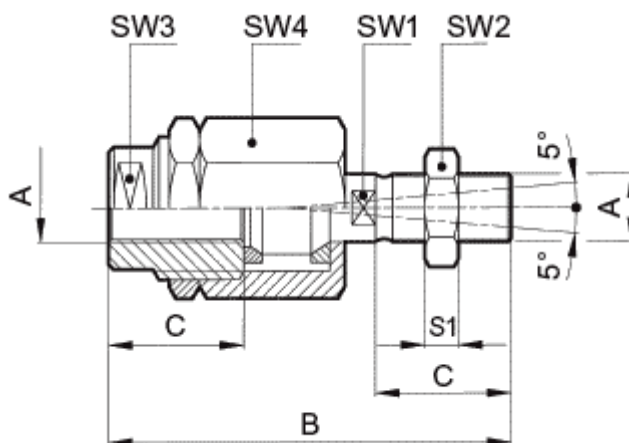

ALESAGGIO	A	B	C	S1	SW1	SW2	SW3	SW4
50	M16X1,5	103	32	8	20	24	30	42
63	M16X1,5	103	32	8	20	24	30	42
80	M20X1,5	119	40	10	20	30	30	42
100	M20X1,5	119	40	10	20	30	30	42



TIPO IKJ**FORCELLA OSCILLANTE - ACCIAIO ZINCATO, COD. IKJ**

Forcella oscillante in acciaio zincato

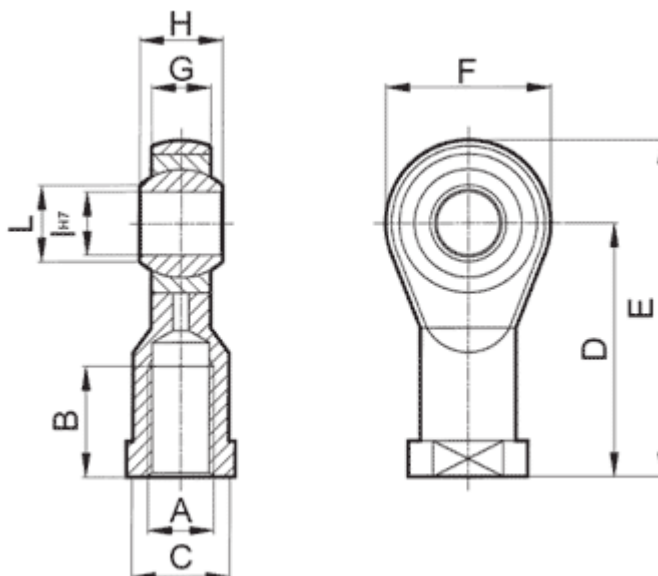

Ø mm	A	B	C	D	E	F	G	H	I	L
50	M16x1,5	28	22	64	85	42	15	21	16	19,3
63	M16x1,5	28	22	64	85	42	15	21	16	19,3
80	M20x1,5	33	30	77	102	50	18	25	20	24,3
100	M20x1,5	33	30	77	102	50	18	25	20	24,3
125	M27x2	51	41	110	145	70	25	37	30	34,8
160	M36x2	56	50	125	165	80	28	43	35	37,7
200	M36x2	56	50	125	165	80	28	43	35	37,7

TIPO SEC**PERNO PER CERNIERA – ACCIAIO, COD. SEC**

Perno per cerniera in acciaio

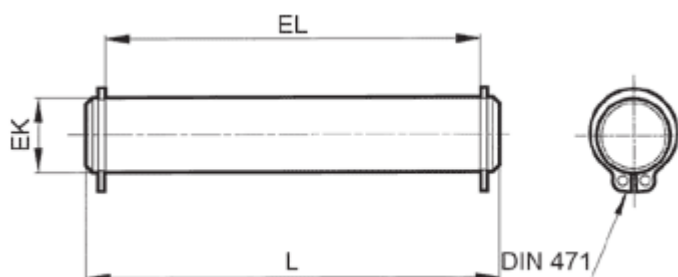

Ø mm	EK e8	EL	L
50	12	38	44
63	16	56	62
80	18	76	82
100	20	76	82
125	25	82	88
160	25	97	103
200	25	162	168