



Special pneumatic cylinders/actuators.
Examples of project realized.



Actuators with mechanical functions/pneumatic motions integrated



Special actuator for locking of mould integrated with cylinder \varnothing 125 mm., stroke 30 mm., double acting, magnetic piston, pneumatic adjustable cushion for the return stroke, front head in steel with piston rod in high resistant steel and thermal treatment for further hardening of the surface, security device for locking of the piston rod in extended position.

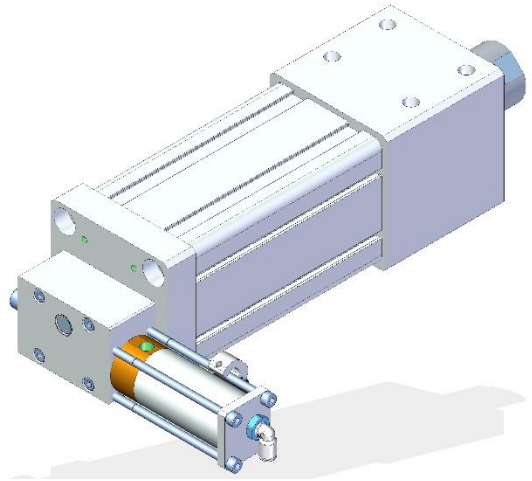

Special actuator with double motions, linear and rotating of the piston rod. Linear cylinder \varnothing 80 mm., stroke 100 mm., piston rod diameter 40 mm., with increased bushing guide, rotation of the piston rod of 90° by grooved rod and bush in sintered bronze. Cylinder for actuating the rotation \varnothing 25 mm., with adjustable stop.

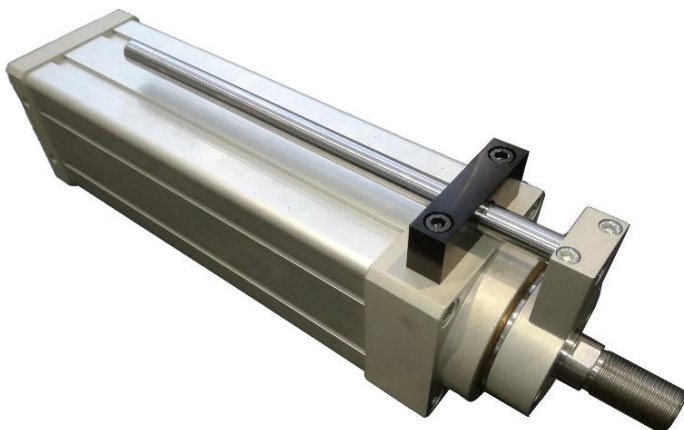

Telescopic cylinder dual steps. First stage \varnothing 100 mm., second stage \varnothing 70 mm., total stroke 550 mm., piston rod in chromium steel C45 diameter 30 mm., anti rotation system on second stage, caps in anodized aluminium, tube of the first stage in profiled aluminium, tube of the second stage in chromium steel E355.



Special pneumatic cylinders/actuators.
Examples of project realized.



Actuators with mechanical functions/pneumatic motions integrated

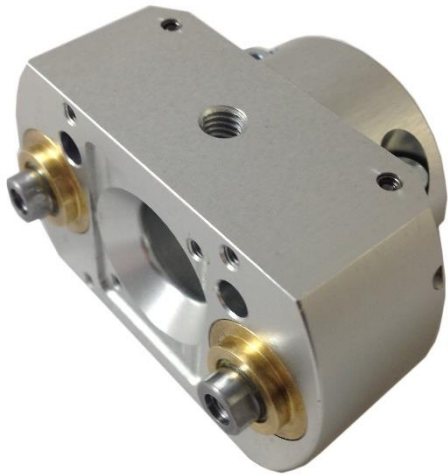

Support for group of automatic changer of clamps with 2 cylinders \varnothing 16 mm. stroke 10 mm. integrated in the body, double acting.



Linear actuators with pneumatic and mechanical motion for filling machines in the “beverage” field, version in aluminium and stainless steel AISI 304.



Special pneumatic cylinders/actuators.
Examples of project realized.



Actuators with mechanical functions/pneumatic motions integrated



Double pointer slide for system of silk-screen printing on products.

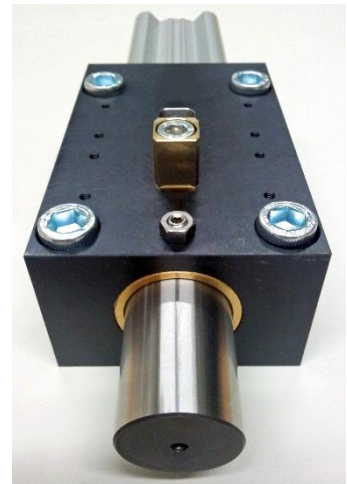
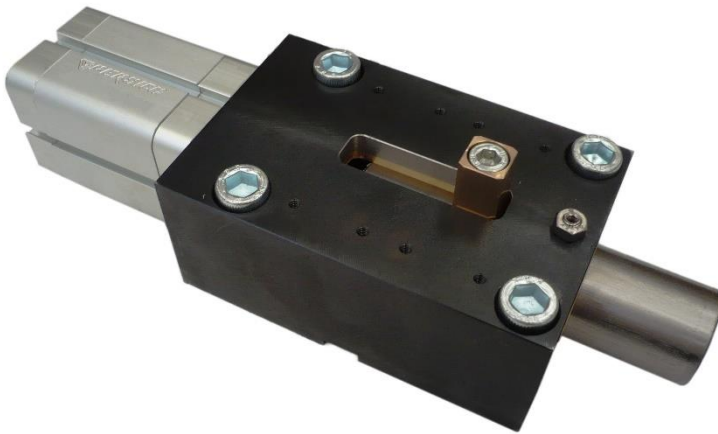

Security bolt with anti-fall device.

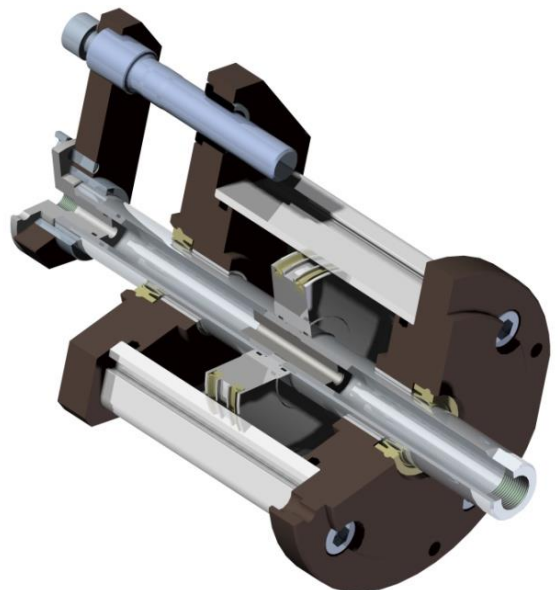

Compact cylinder \varnothing 80 mm., stroke 60 mm., with double ended piston rod with internal through hole and guide with high precision antirotation system.



Special pneumatic cylinders/actuators.
Examples of project realized.



Actuators with mechanical functions/pneumatic motions integrated

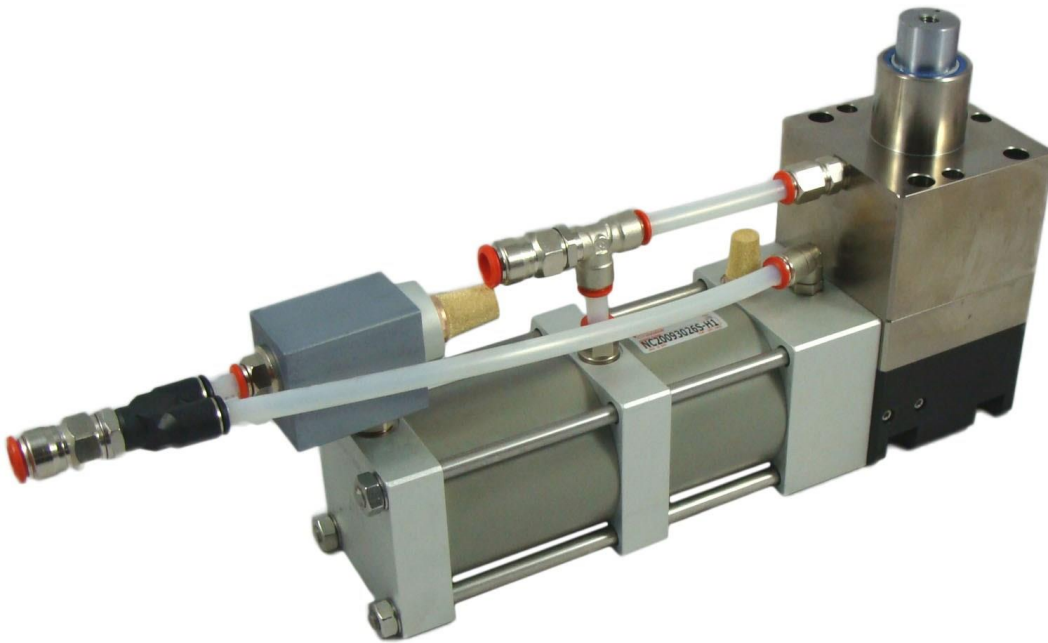

Special actuator for “mould closure” with tandem pneumatic cylinder \varnothing 80 mm. and cylinder \varnothing 63 mm., angular mechanical group for increasing the force, piston rod in high resistant steel, piston rod seals and grease certificated for food industry.

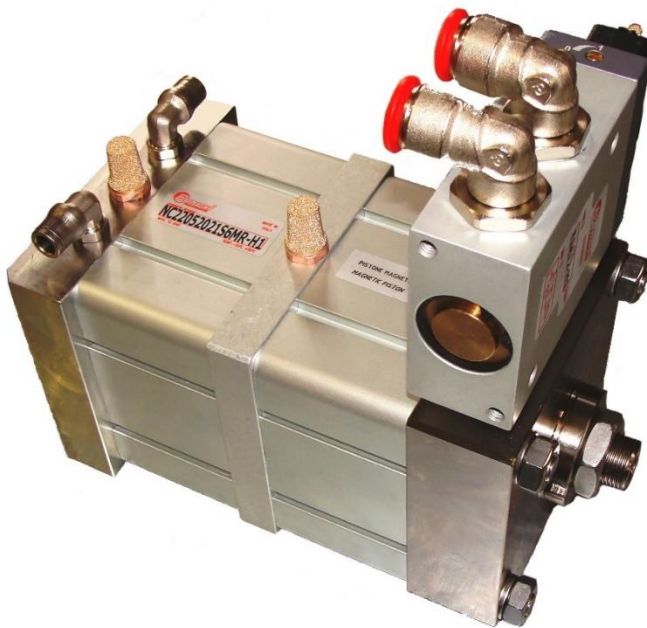

Tandem compact cylinder, double thrust, \varnothing 100 mm., double acting, magnetic piston, mechanical adjustment of the return stroke and with integrated control solenoid valve.